

www.prexiso-eu.com

PREXISO

- EN MECHANICAL DISTANCE MEASURING WHEEL
- DE MECHANISCHER ABSTANDS MESSRAD
- FR ROUE DE MESURE DE DISTANCE MÉCANIQUE
- IT RUOTA DI MISURA MECCANICA DELLA DISTANZA
- ES RUEDA DE MEDICIÓN DE DISTANCIA MECÁNICA
- NL MECHANISCHE AFSTAND MEETWIEL
- TR MEKANİK MESAFE ÖLÇÜM ÇARKI
- DK MEKANISK AFSTAND MÅLINGHJUL
- FI MEKAANINEN ETÄISYYDEN MITTAUSPYÖRÄ
- NO MEKANISK AVSTAND MÅLINGHJUL

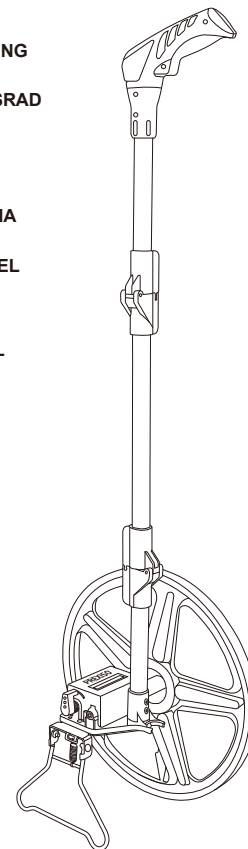

Fabrikstrasse 1
CH-8586 Erlen /Switzerland

www.prexiso-eu.com

IMPORTANT:
Read before Using

EN



The safety instructions and the user manual should be read through carefully before the product is used for the first time.

SAFETY INSTRUCTION:

Be sure to return the counter to zero before measuring.

1. If a line measured, the accuracy of the measurement is guaranteed.
2. Don't measure the uneven surface, or it will reduce the accuracy of the measurement.
3. Don't measure in the rain for long.
4. Don't measure in a high temperature environment. Don't store the instrument at high temperature.
5. Do not use this instrument as a child's toy to avoid unwanted damage.

PROHIBITED USE

- Using the product without instruction
- Using outside the stated limits
- Deactivation of safety systems and removal of explanatory and hazard labels
- Opening of the equipment by using tools (screwdrivers, etc.)
- Carrying out modification or conversion of the product
- Use of accessories from other manufacturers without express approval

LIMITS OF USE

Never attempt to repair the product yourself. In case of damage, contact a local dealer. Refer to section "Technical data", the device is designed for using in areas which is habitable for humans.

Do not use the product in explosion hazardous areas or in aggressive environments.

**AREAS OF RESPONSIBILITY
RESPONSIBILITIES OF THE PERSON IN
CHARGE OF THE INSTRUMENT:**

- To understand the safety instructions on the product and the instructions in the User Manual.
- To be familiar with local safety regulations relating to accident prevention.
- Always prevent access to the product by unauthorized personnel.

FUNCTION

This mechanical measuring wheel is a kind of distance tools of measurement. Widely used in traffic road site measurement, ordinary construction, pave road, or yard survey. This measuring wheel can measure up to 9999 11/12 ft. The folding rod makes the measuring wheel easy to carry.

PRODUCT OVERVIEW

- A. Rubber handle
- B. Folding rod
- C. Rod locking & folding knob
- D. Measuring wheel with 39.4in. circumference
- E. Kickstand(fold-out)
- F. Moving pointer for start and end position
- G. Mechanical counter
- H. Reset knob

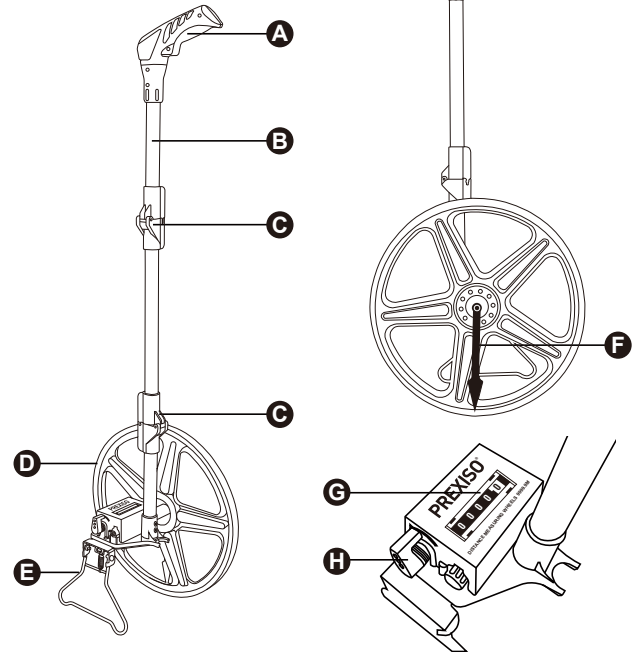

OPERATION INSTRUCTION

1. Unfold the distance measuring wheel.

Straighten two folding knobs to unfold and fix the rod based on the following illustration.

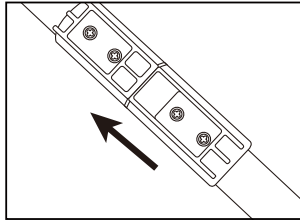
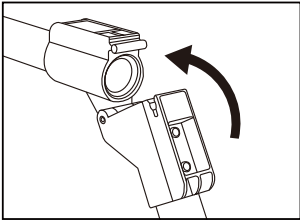

2. Reset the measurement

Toggle the Reset knob to make the mechanical counter to zero.

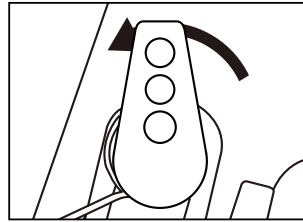

3. Measure the distance from wall to wall

- Position the wheel against the wall and reset the counter.
- Push the wheel straight to the other wall.
- Read the measured value and add diameter of the wheel when measurement is finished.

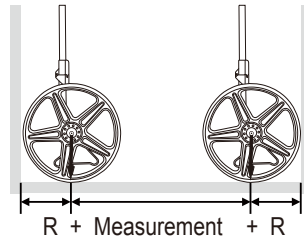

4. Measure the distance from spot to wall

- Position the wheel from the beginning spot and reset the counter.
- Push the wheel straight to the wall.
- Read the measured value and add radius of the wheel when measurement is finished.

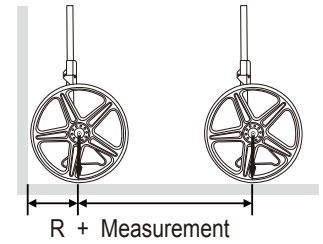

5. Measure the distance from spot to spot

- Position the wheel from the beginning spot and reset the counter.
- Push the wheel straight to the other spot.
- Read the measured value.

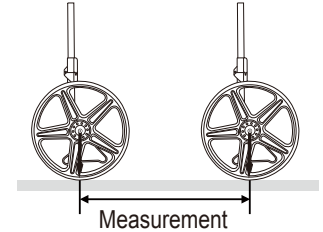

6. Fold for carrying

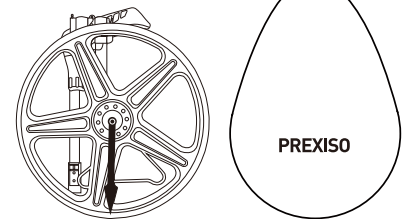
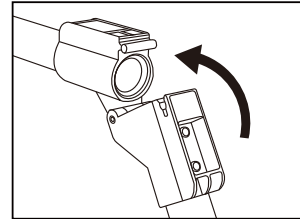

Technical specification	
Measuring range	0~9999 11/12 ft
Accuracy	±0.30%
Minimum display value	1/12ft
Measuring unit	ft
Circumference of measuring wheel	39.4in.(1000mm)
Diameter of measuring wheel	12.5in.(318mm)
Operating temperature	14°F to 113°F (-10°C to 45°C)
Extended	39.4in.(1000mm)
Length Folded	14.4in.(365mm)
Weight	37.39oz. (1060g)
Dimensions (L x W x H)	extended: 39.4x12.5x7.28in.(1000x318x185mm) folded: 14.4x12.5x7.28in. (365x318x185mm)

WARRANTY

The Instrument PWX-1000MS has a two-year warranty. This product is warranted to the original purchaser from the original purchase date for two years subject to the warranty coverage described herein. Please retain your receipt. This product is warranted to the original user to be free from defects in material and workmanship. If you believe that the product is defective at any time during the specified warranty period, pls contact Prexiso customer service agent by sending email to info@prexiso-eu.com. This warranty does not cover:(1) Part failure due to normal wear or product abuse;(2) Any parts have been altered or modified by anyone other than an authorized Prexiso personnel or failure to install and operate equipment according to the guidelines put forth in the instruction manual.(3)Any products or parts used for rental purposes, damage resulting from shipping (claims must be filed with freighter), accident,abuse, act of God, misuse, or neglect. Prexiso will replace or repair the defective unit, at its option, subject to verification of the defect. Any implied warranties arising from the sale of a Prexiso product, including but not limited to implied warranties of merchantability and fitness for a particular purpose, are limited to the above. Prexiso shall not be liable for loss of use of the product or other incidental or consequential damages,expenses, or economic loss, or for any claim of such damage, expenses,or economic loss. This warranty excludes any accessories. This warranty gives you specific legal rights, and you may also have other rights that vary from state.